



RPS-412A Analog Current High Accuracy Ultrasonic Sensor

Features

- Input Voltage 20 - 30VDC
- Temperature Compensation
- Analog Current Output
- Self Contained Sensor
- Short Circuit Protected
- Quick Disconnect Connector
- Wide Temperature Range
- Stainless Steel Housing

The RPS-412A is a high accuracy analog ultrasonic sensor ($\pm 0.002''$ or 0.05% of range, whichever is greater, at 25°C) with a resolution of 0.0005". The sensor monitors and compensates for air temperature 50 times per second, using the temperature compensation bar located in front of the transducer. This temperature compensation method also compensates for changes in relative humidity, changes in barometric pressure, and other factors that influence the speed of sound.

The RPS-412A has a 47mm stainless steel barrel housing. The stainless steel housing is electrically isolated from the sensor electronics. The sensor comes with two jam nuts for mounting.

The RPS-412A has a 4 - 20mA analog output. The analog output is a fixed mA per inch. The RPS-412A-16-A is 1.231mA per inch and the RPS-412A-10-A is 2.286mA per inch. For example, when using the RPS-412A-16-A



model, a target placed 3" from the transducer face will result in a sensor output of 20.00mA and a target placed 16" from the transducer face will result in a sensor output of 4.00mA. The RPS-412A is also available with a 0-10V analog voltage output. Please contact Migatron for more information on the analog voltage models, and to discuss your application.

The RPS-412A is designed to take advantage of today's PLC and computer analog input cards. The analog input card will determine the resolution of the system. The analog-to-digital conversion should have, at least, 14 bit resolution. The numerical values programmed into the PLC or computer will determine the zero and span.

If two RPS-412A sensors are used next to each other cross-talk interference may occur between the two sensors. In this case the two sensors should be synchronized (Sync) to prevent cross-talk. In some applications the sensor may need to stop transmitting (Tx) and receiving sound at certain times. With the Tx option the user can control when the sensor transmits. Please contact Migatron for more information on models with the Sync/Tx option, and to discuss your application.

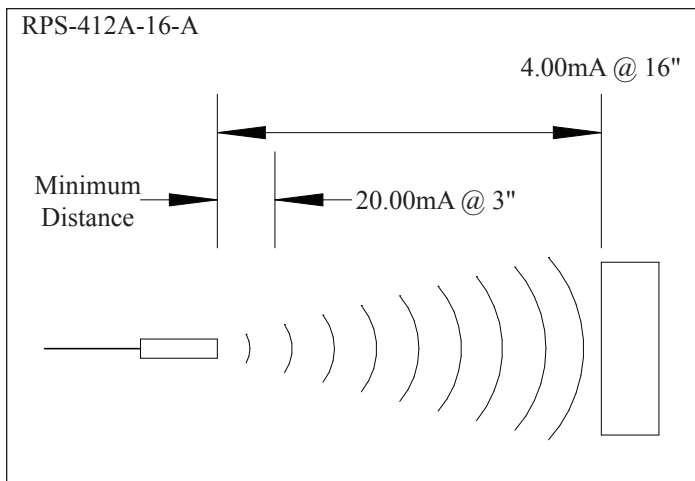

RPS-412A Setup, Calibration & Wiring Instructions

Air Temperature:

The air temperature between the sensor and target must be constant. Any variations in air temperature will compromise the accuracy of the sensor. The sensor can compensate for changes in air temperature provided the air temperature is constant between the sensor and target. If the air temperature varies between the sensor and target the sensor cannot compensate for the temperature variation. For example: If the air temperature is 20°C from the sensor face to 5", and the air temperature is 25°C from 5" to 10". The sensor will compensate for the 20°C air temperature, and ignore the 25°C air temperature.

Sensor Alignment:

The sensor must be properly aligned to obtain the best accuracy. In general the target should be perpendicular to the center line of the sensor. To align the sensor manually place the target you will be measuring at the farthest distance it will be from the sensor. Monitor the color of the LED on the sensor (green is no signal, light red is a weak signal, and bright red is a strong signal) align the sensor, so the LED is the brightest red color you can get. This will be the optimum alignment of the sensor.

Calibration:

The sensor comes pre calibrated from the factory. The factory calibration is performed at the minimum and maximum range of the sensor. With a target at the minimum range, 3" from the transducer face, the output is adjusted to 20.00mA. With a target at the maximum range, 10" from the transducer face for the RPS-412A-10-A or 16" from the transducer face for the RPS-412A-16-A, the output is adjusted to 4.00mA. The sensor may also be re-calibrated in the field. Follow the example below to re-calibrate the sensor in the field to any distances within the range of the sensor.

1. Check Sensor Alignment before calibration, see Sensor Alignment above.
2. P1 must be adjusted first.
3. Place the target at the near distance (closest distance target will get to sensor). Measure the distance from the target to the temperature compensation bar. **(Do not touch the face of the transducer.)**

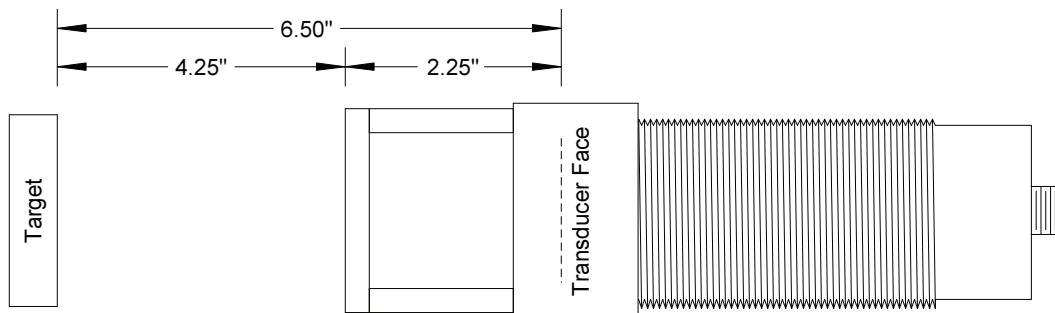

4. Calculate the current for the near distance. First subtract 0.75" from the measured distance and then multiply by the mA per inch. Second subtract the pervious result from 20mA. Adjust P1 for the calculated current.





RPS-412A-10-A: 1) $4.25'' - 0.75'' = 3.50'' \times 2.286\text{mA}/'' = 8.00\text{mA}$
 2) $20.00\text{mA} - 8.00\text{mA} = 12.00\text{mA}$

RPS-412A-16-A: 1) $4.25'' - 0.75'' = 3.50'' \times 1.231\text{mA}/'' = 4.31\text{mA}$
 2) $20.00\text{mA} - 4.31\text{mA} = 15.69\text{mA}$

5. Place the target at the far distance (farthest distance target will be from sensor). Measure the distance from the target to the temperature compensation bar. **(Do not touch the face of the transducer.)**

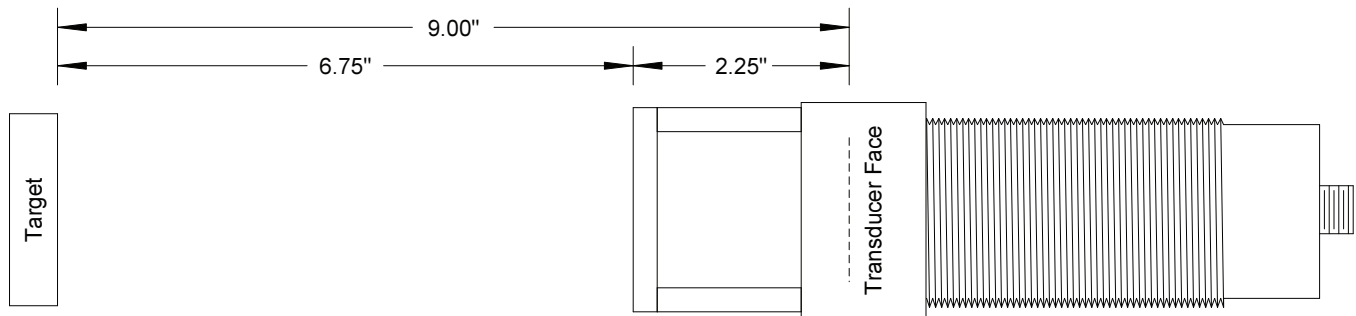

6. Calculate the current for the far distance. First subtract 0.75" from the measured distance and then multiply by the mA per inch. Second subtract the pervious result from 20mA. Adjust P2 for the calculated current.

RPS-412A-10-A: 1) $6.75'' - 0.75'' = 6.00'' \times 2.286\text{mA}/'' = 13.72\text{mA}$
 2) $20.00\text{mA} - 13.72\text{mA} = 6.28\text{mA}$

RPS-412A-16-A: 1) $6.75'' - 0.75'' = 6.00'' \times 1.231\text{mA}/'' = 7.39\text{mA}$
 2) $20.00\text{mA} - 7.39\text{mA} = 12.61\text{mA}$

7. Repeat the adjustment of P1 and P2 one or more times to achieve the best accuracy.

Wiring:

The RPS-412A has three ground (GND) wires. Power GND and Analog Signal GND are connected together inside the sensor. However, when installing the sensor it is important to connect the Power GND to the power supply GND and Analog Signal GND to the minus input of the PLC. This configuration is intended to keep GND currents associated with powering the sensor on the Power GND wire while maintaining a clean GND connection for the Analog Signal via the Analog Signal GND.

The third GND is Case GND. The stainless steel housing (case) is connected to the metal shell of the M12 receptacle, located on the back of the sensor. By using a shielded M12 cable, with the shield connected to the coupling nut of the cable, the case can be grounded with the drain wire from the shielded M12 cable. Other grounding configurations are possible, and may need to be explored if GND noise is interfering with the operation of the sensor.

Specifications:

Model:	Range:	mA per Inch:
RPS-412A-10-A	3 - 10"	2.286mA
RPS-412A-16-A	3 - 16"	1.231mA
Accuracy:	±0.002", or ± 0.05% of range (which ever is greater) @ 25°C. ±0.2% of range from 0 - 50°C	
Resolution:	0.0005"	
Power Input:	20 - 30VDC Reverse Polarity Protected	
Input Current:	65mA Typical	
Operating Temperature:	0 - 50°C or 32 - 122°F	
Humidity:	0 - 95% Non-Condensing	
Output:	Current Sourcing Analog Output 4 - 20mA Load 0 Ohms to 500 Ohms, Maximum	
Transducer Frequency:	60kHz	
Housing:	Stainless Steel	
Protection:	IP10	
Sample Rate:	20ms Typical	
Update Time:	2s Maximum	
Weight:	22 ounces	

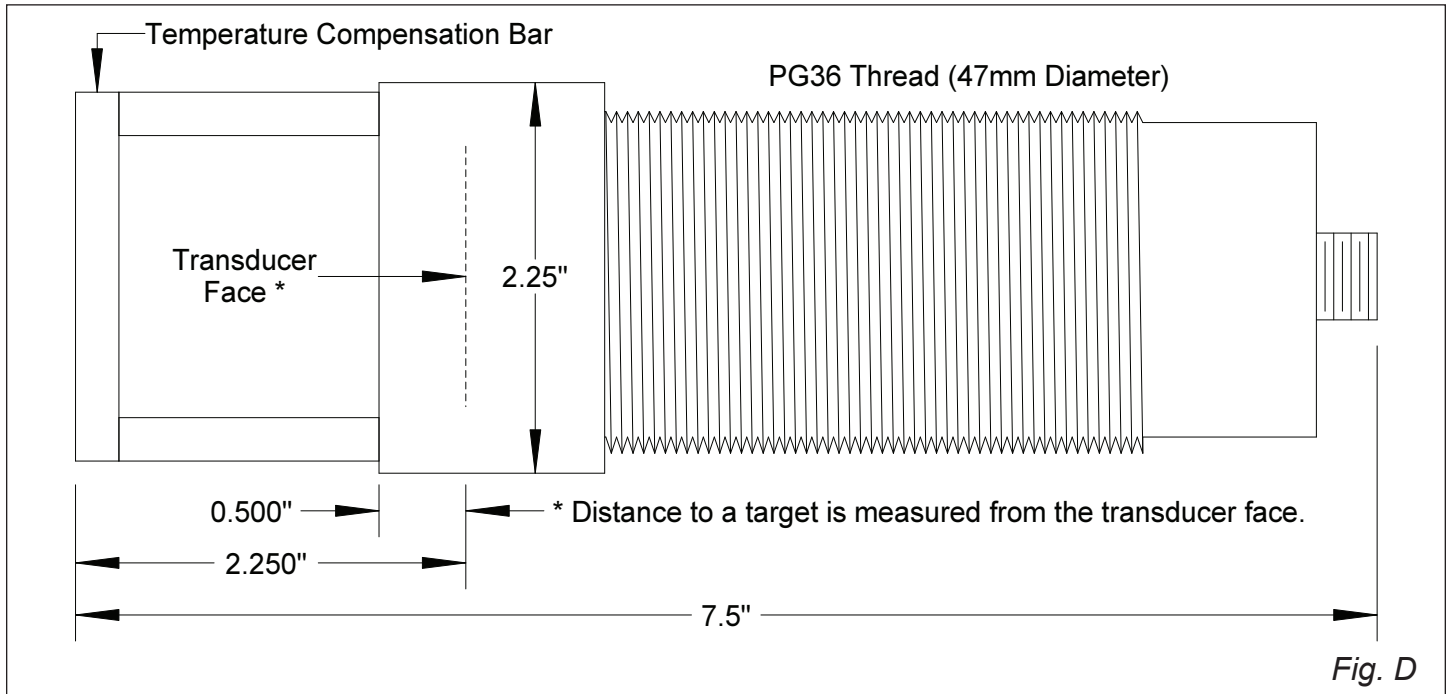
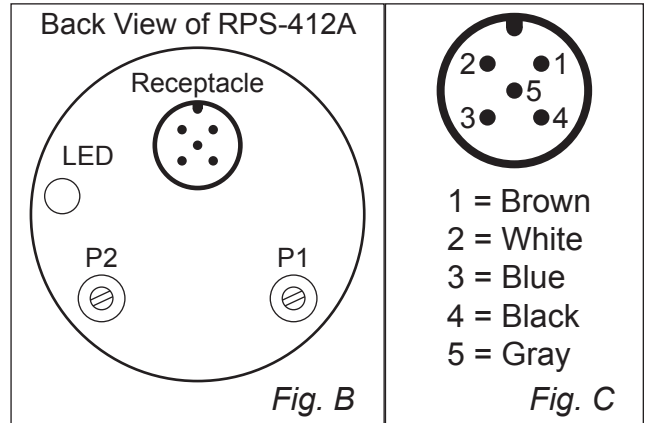
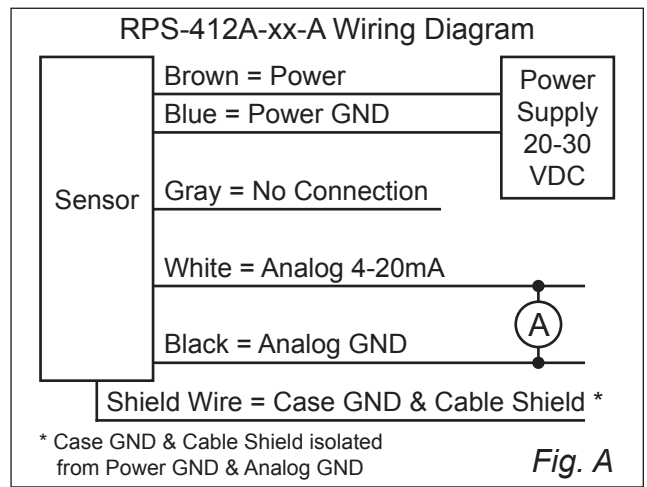

PART NUMBER	RANGE	OUTPUT / DESCRIPTION
RPS-412A-10-A	3 - 10"	4 - 20mA Analog Current Output - Cable Sold Separately
RPS-412A-16-A	3 - 16"	4 - 20mA Analog Current Output - Cable Sold Separately
F32-5001300		2 meter QD Cable, M12 5-Pin 22 AWG Shielded

